

3 YOLLU "L" TİPİ CEKETLİ KÜRESEL VANA

3 WAYS "L" TYPE JACKET BALL VALVE

TİP TYPE
BKV.3L-CEK-FL-TG

DN 15 - DN 150

PN 16 - PN 40

ÇELİK
STELL

TAM GEÇİŞLİ / FLANŞLI
FULL BORE / FLANGED

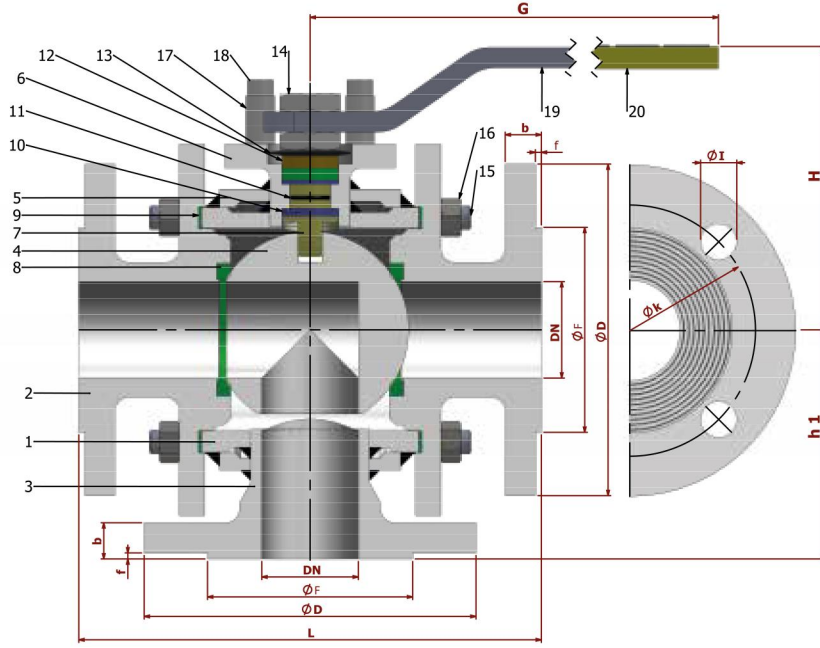

PARÇA NO ITEM NO	PARÇA ADI ITEM DISCRPTION	MALZEME MATERIAL
20	PLASTİK KAPLAMA PLASTIC COVERING	PVC / PVC
19	KÜRE HAREKET KOLU BALL ACTION HANDLE	st 37 / 1.4301.
18	ÇİVATA BOLT	ST 42 Gal. / 1.4301. - 1.4401.
17	STOPLAMA PİMİ STOPPING PIM	ST 42 Gal. / 1.4301.
16	SOMUN NUT	5.6. / 1.4301. - 1.4401.
15	ŞAPLAMA STOPPING PIM	CK 35 / CK 45 / 1.4301.
14	KONTRA SOMUN COUNTER NUT	5,6 Gal. / 1.4301.
13	ÇANAK PUL BOWL WASHER	50 Cr V 4 / 1.4301.
12	BASKI RİNGİ PRESSURE RING	MS 58 / 1.4301. - 1.4401.
11	MİL O-RİNG SPINDLE O-RING	VİTON / VİTON
10	BOĞAZ SIZDIRMAZLIK TEFLONU NECK TIGHTNESS ELEMENT	PTFE-Teflon / PTFE-Teflon
9	GÖVDE SIZDIRMAZLIK TEFLONU BODY TIGHTNESS ELEMENT	PTFE-Teflon / PTFE-Teflon
8	KÜRE SIZDIRMAZLIK TEFLONU BALL TIGHTNESS ELEMENT	PTFE-Teflon / PTFE-Teflon
7	HAREKET MİLİ ACTION SPINDLE	1.4021 / 1.4301. - 1.4401.
6	BOĞAZ NECK	St 37-2 / 1.4301. - 1.4401.
5	CEKET JACKET	St 44 / 1.4301. - 1.4401.
4	KÜRE BALL	1.4301 / 1.4086 / 1.4305. - 1.4401.
3	3 YOL KAPAK COVER 3 WAY	St 37-2 / 1.4301. - 1.4401.
2	KAPAK COVER	St 37-2 / 1.4301. - 1.4401.
1	GÖVDE BODY	A 216 WCB / 1.4301. - 1.4401.

Boyut Dimensions : EN 558
Bağlantılar Connections : EN 1092 - 1
Çalışma Basıncı Working Pressure : PN 16 - 40
Çalışma Sıcaklığı Working Temperature: +180 °C

Kullanım Alanları Usege Areas :
Asfalt, Gıda ve Kimya Sanayii
Asphalt, Good ang Chemical Ind.



BOYUT ve BAĞLANTI ÖLÇÜLERİ DIMENSIONS AND CONNECTION SIZES

		PN 16											PN 40							
		L	G	H	h1	f	D	b	k	Hole Unit	I	F	Kg	D	b	k	Hole Unit	I	F	Kg
DN 15	1/2"	130	150	75	65	2	95	14	65	4	14	45	--	95	16	65	4	14	45	--
DN 20	3/4"	150	180	90	75	2	105	16	75	4	14	58	--	105	18	75	4	14	58	--
DN 25	1"	160	230	95	80	2	115	16	85	4	14	68	--	115	18	85	4	14	68	--
DN 32	1 1/4"	180	275	115	90	2	140	16	100	4	18	78	--	140	18	100	4	18	78	--
DN 40	1 1/2"	200	275	120	100	3	150	16	110	4	18	88	--	150	18	110	4	18	88	--
DN 50	2"	230	320	135	115	3	165	18	125	4	18	102	--	165	20	125	4	18	102	--
DN 65	2 1/2"	290	380	150	145	3	185	18	145	4	18	122	--	185	22	145	8	18	122	--
DN 80	3"	310	450	170	170	3	200	20	160	8	18	138	--	200	24	160	8	18	138	--
DN 100	4"	350	450	200	175	3	220	20	180	8	18	158	--	235	24	190	8	22	162	--
DN 125	5"	400	650	235	200	3	250	22	210	8	18	188	--	270	26	220	8	26	188	--
DN 150	6"	450	900	270	270	3	285	22	240	8	22	212	--	300	28	250	8	26	218	--